

HYDRAULIC MOTORS SP

M+S Hydraulic introduces a new version of hydraulic motors, type SP with new housing, integrated output shaft to the spool valve, check valves, high pressure shaft seal. The SP motors are suitable for a wide range of applications where compact and high efficient motors are required.

CONTENTS

Specification data	45÷46
Function diagrams	18÷24
Dimensions and mounting	47÷48
Shaft extensions	48
Permissible shaft Seal Pressure ...	48
Permissible shaft loads	49
Order code	49

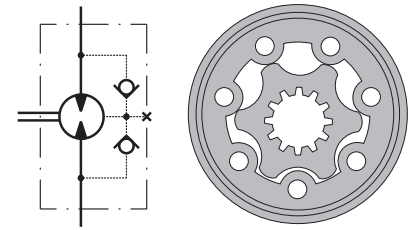

APPLICATION

- » Conveyors
- » Feeding mechanism of robots and manipulators
- » Metal working machines
- » Textile machines
- » Agriculture machines
- » Food industries
- » Grass cutting machinery etc.

OPTIONS

- » Model- Spool valve, gerotor
- » Flange mount - 2 hole oval flange; square flange
- » Side BSPP ports
- » Shafts- straight and splined
- » Shaft seal for high and low pressure
- » Other special features

GENERAL

Max. Displacement, cm ³ /rev [in ³ /rev]	396 [24.16]
Max. Speed, [RPM]	1515
Max. Torque, daNm [lb-in]	cont.:38 [3360] int.: 46 [3240]
Max. Output, kW [HP]	17,5 [23.5]
Max. Pressure Drop, bar [PSI]	cont.:140 [2030] int.:175 [2540]
Max. Oil Flow, lpm [GPM]	75 [19.8]
Min. Speed, [RPM]	10
Pressure fluid	Mineral based- HLP(DIN 51524) or HM(ISO 6743/4)
Temperature range, °C [°F]	-30÷90 [-22÷194]
Optimal Viscosity range, mm ² /s [SUS]	20÷75 [98÷347]
Filtration	ISO code 20/16 (Min. recommended fluid filtration of 25 micron)

Oil flow in drain line

Pressure drop bar [PSI]	Viscosity mm ² /s [SUS]	Oil flow in drain line lpm [GPM]
100 [1450]	20 [98]	2,5 [.660]
	35 [164]	1,8 [.476]
140 [2030]	20 [98]	3,5 [.925]
	35 [164]	2,8 [.740]

Pressure Losses

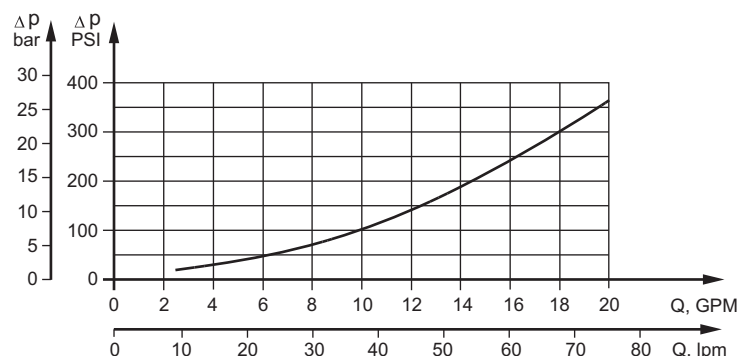

SPECIFICATION DATA

Specification Data for SP... motors with **C** and **CO** shafts.

Type		SP 50	SP 80	SP 100	SP 125	SP 160	SP 200	SP 250	SP 315	SP 400
Displacement, cm³/rev [in³/rev]		49,5 [3.0]	79,2 [4.83]	99 [6.04]	123,8 [7.55]	158,4 [9.66]	198 [12.1]	247,5 [15.1]	316,8 [19.3]	396 [2416]
Max. Speed, [RPM]	Cont.	1210	755	605	486	378	303	242	190	150
	Int.*	1515	945	755	605	472	378	303	236	189
Max. Torque daNm [lb-in]	Cont.	9,4 [835]	15,1 [1340]	19,3 [1710]	23,7 [2100]	30 [2655]	30 [2655]	27,6 [2442]	29,5 [2610]	28,5 [2522]
	Int.*	11,9 [1050]	19,5 [1725]	23,7 [2100]	29,8 [2640]	37,8 [3345]	36,5 [3230]	35,5 [3142]	36,6 [4070]	36 [3185]
	Peak**	14 [1240]	22 [1950]	27 [2390]	36,5 [3230]	42 [3717]	53 [4690]	54 [4780]	59 [5222]	59 [5222]
Max. Output kW [HP]	Cont.	9,9 [13.3]	9,9 [13.3]	9,9 [13.3]	9,9 [13.3]	9,9 [13.3]	9,5 [12.7]	6 [8.1]	4 [5.4]	3 [4]
	Int.*	12,5 [16.8]	12,5 [16.8]	12,5 [16.8]	12,5 [16.8]	12,5 [16.8]	12,5 [16.8]	13,2 [17.7]	5,8 [7.8]	5 [6.7]
Max. Pressure Drop bar [PSI]	Cont.	140 [2030]	140 [2030]	140 [2030]	140 [2030]	140 [2030]	115 [1670]	85 [1233]	70 [1015]	55 [798]
	Int.*	175 [2540]	175 [2540]	175 [2540]	175 [2540]	175 [2540]	140 [2030]	110 [1450]	90 [1305]	70 [1015]
	Peak**	225 [3260]	225 [3260]	225 [3260]	225 [3260]	225 [3260]	225 [3260]	180 [2610]	160 [2320]	130 [1885]
Max. Oil Flow lpm [GPM]	Cont.	60 [15.9]	60 [15.9]	60 [15.9]	60 [15.9]	60 [15.9]	60 [15.9]	60 [15.9]	60 [15.9]	60 [15.9]
	Int.*	75 [19.8]	75 [19.8]	75 [19.8]	75 [19.8]	75 [19.8]	75 [19.8]	75 [19.8]	75 [19.8]	75 [19.8]
Max. Starting Pressure with Unloaded Shaft, bar [PSI]		10 [145]	10 [145]	10 [145]	9 [131]	8 [116]	7 [100]	6 [87]	5 [73]	5 [73]
Min. Starting Torque, daNm [lb-in]		7,7 [682]	14 [1240]	16,8 [1490]	21 [1860]	28 [2478]	28,5 [2522]	26,5 [2345]	26,5 [2345]	26,5 [2345]
Max. Inlet Pressure bar [PSI]	Cont.	175 [2540]	175 [2540]	175 [2540]	175 [2540]	175 [2540]	175 [2540]	175 [2540]	175 [2540]	175 [2540]
	Int.*	200 [2900]	200 [2900]	200 [2900]	200 [2900]	200 [2900]	200 [2900]	200 [2900]	200 [2900]	200 [2900]
	Peak**	225 [3260]	225 [3260]	225 [3260]	225 [3260]	225 [3260]	225 [3260]	225 [3260]	225 [3260]	225 [3260]

* Intermittent operation: the permissible values may occur for max. 10% of every minute.

** Peak load: the permissible values may occur for max. 1% of every minute.

*** For speeds lower than given, consult factory or your regional manager.

1. Intermittent speed and intermittent pressure must not occur simultaneously.
2. Recommended filtration is per ISO cleanliness code 20/16. A nominal filtration of 25 micron or better.
3. Recommend using a premium quality, anti-wear type mineral based hydraulic oil HLP(DIN51524) or HM (ISO 6743/4).
If using synthetic fluids consult the factory for alternative seal materials.
4. Recommended minimum oil viscosity 13 mm²/s [70 SUS] at 50°C [122°F].
5. Recommended maximum system operating temperature is 82°C [180°F].
6. To assure optimum motor life fill with fluid prior to loading and run at moderate load and speed for 10-15 minutes.

SPECIFICATION DATA

Specification Data for SP... motors with **SH** shafts.

Type		SP 50	SP 80	SP 100	SP 125	SP 160	SP 200	SP 250	SP 315	SP 400
Displacement, cm³/rev [in³/rev]		49,5 [3.0]	79,2 [4.83]	99 [6.04]	123,8 [7.55]	158,4 [9.66]	198 [12.1]	247,5 [15.1]	316,8 [19.3]	396 [2416]
Max. Speed, [RPM]	Cont.	1210	755	605	486	378	303	242	190	150
	Int.*	1515	945	755	605	472	378	303	236	189
Max. Torque daNm [lb-in]	Cont.	9,4 [835]	15,1 [1340]	19,3 [1710]	23,7 [2100]	30 [2655]	36,6 [3240]	38 [3360]	38 [3360]	36 [3190]
	Int.*	11,9 [1050]	19,5 [1725]	23,7 [2100]	29,8 [2640]	37,8 [3345]	45,6 [4035]	45 [3980]	46 [3240]	46 [3240]
	Peak**	14 [1240]	22 [1950]	27 [2390]	36,5 [3230]	42 [3717]	53 [4690]	67 [5930]	85 [7523]	85 [7523]
Max. Output kW [HP]	Cont.	9,9 [13.3]	9,9 [13.3]	9,9 [13.3]	9,9 [13.3]	9,9 [13.3]	10,3 [13.8]	8 [10.7]	6 [8.1]	4,8 [6.4]
	Int.*	12,5 [16.8]	12,5 [16.8]	12,5 [16.8]	12,5 [16.8]	12,5 [16.8]	15,3 [20.5]	17,5 [23.5]	8,2 [10.9]	9,2 [12.3]
Max. Pressure Drop bar [PSI]	Cont.	140 [2030]	140 [2030]	140 [2030]	140 [2030]	140 [2030]	140 [2030]	110 [1450]	90 [1305]	70 [1015]
	Int.*	175 [2540]	175 [2540]	175 [2540]	175 [2540]	175 [2540]	175 [2540]	140 [2030]	140 [2030]	90 [1305]
	Peak**	225 [3260]	225 [3260]	225 [3260]	225 [3260]	225 [3260]	225 [3260]	225 [3260]	225 [3260]	180 [2610]
Max. Oil Flow lpm [GPM]	Cont.	60 [15.9]	60 [15.9]	60 [15.9]	60 [15.9]	60 [15.9]	60 [15.9]	60 [15.9]	60 [15.9]	60 [15.9]
	Int.*	75 [19.8]	75 [19.8]	75 [19.8]	75 [19.8]	75 [19.8]	75 [19.8]	75 [19.8]	75 [19.8]	75 [19.8]
Max. Starting Pressure with Unloaded Shaft, bar [PSI]		10 [145]	10 [145]	10 [145]	9 [131]	8 [116]	7 [100]	6 [87]	5 [73]	5 [73]
Min. Starting Torque, daNm [lb-in]		7,7 [682]	14 [1240]	16,8 [1490]	21 [1860]	28 [2478]	34,6 [3062]	34,5 [3050]	35 [3098]	35 [3098]
Max. Inlet Pressure bar [PSI]	Cont.	175 [2540]	175 [2540]	175 [2540]	175 [2540]	175 [2540]	175 [2540]	175 [2540]	175 [2540]	175 [2540]
	Int.*	200 [2900]	200 [2900]	200 [2900]	200 [2900]	200 [2900]	200 [2900]	200 [2900]	200 [2900]	200 [2900]
	Peak**	225 [3260]	225 [3260]	225 [3260]	225 [3260]	225 [3260]	225 [3260]	225 [3260]	225 [3260]	225 [3260]

* Intermittent operation: the permissible values may occur for max. 10% of every minute.

** Peak load: the permissible values may occur for max. 1% of every minute.

*** For speeds lower than given, consult factory or your regional manager.

1. Intermittent speed and intermittent pressure must not occur simultaneously.
2. Recommended filtration is per ISO cleanliness code 20/16. A nominal filtration of 25 micron or better.
3. Recommend using a premium quality, anti-wear type mineral based hydraulic oil HLP(DIN51524) or HM (ISO 6743/4).
If using synthetic fluids consult the factory for alternative seal materials.
4. Recommended minimum oil viscosity 13 mm²/s [70 SUS] at 50°C [122°F].
5. Recommended maximum system operating temperature is 82°C [180°F].
6. To assure optimum motor life fill with fluid prior to loading and run at moderate load and speed for 10-15 minutes.

DIMENSIONS AND MOUNTING DATA

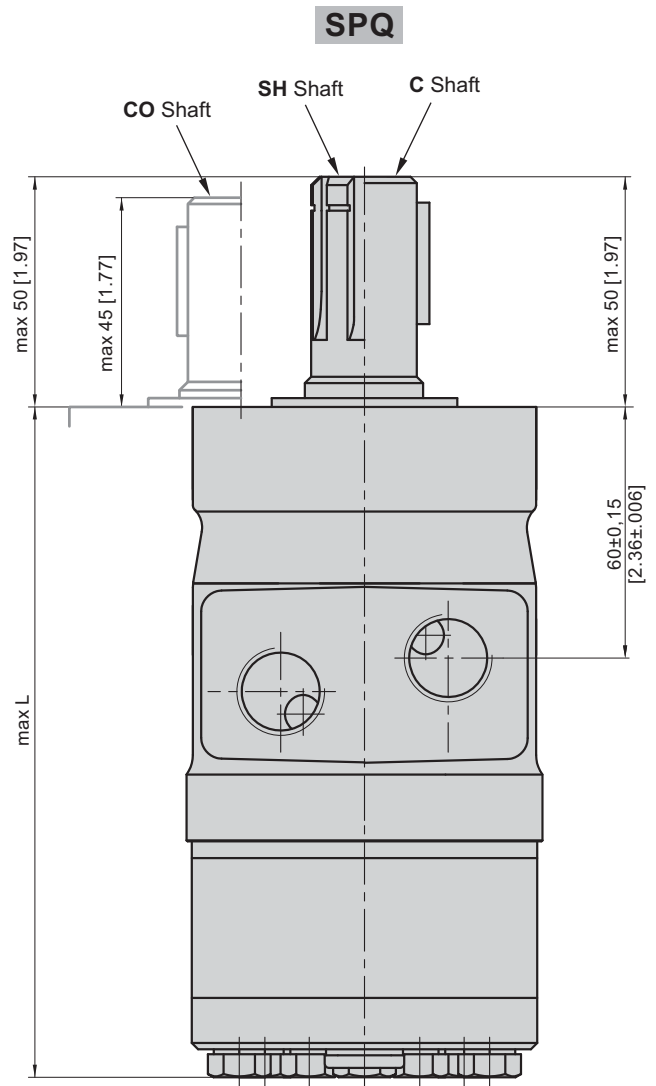
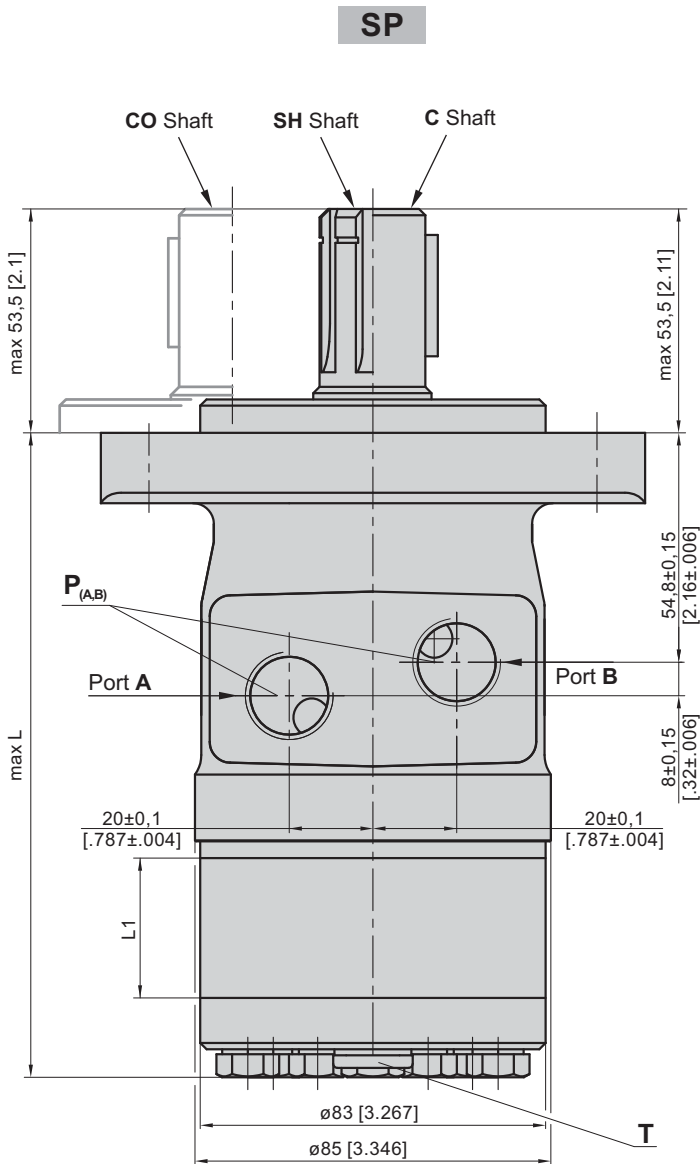

P_(A,B): 2xG1/2 - 18 mm [.709 in] depth
T: G1/4 - 12 mm [.47 in] depth

Type	L _{max} , mm [in]	Type	L _{max} , mm [in]	L ₁ , mm [in]
SP 50	128 [5.04]	SPQ 50	134 [5.28]	6,67 [.26]
SP 80	132 [5.19]	SPQ 80	138 [5.43]	10,67 [.42]
SP 100	134,5 [5.29]	SPQ 100	140,9 [5.55]	13,33 [.52]
SP 125	138 [5.43]	SPQ 125	144 [5.67]	16,67 [.66]
SP 160	142,5 [5.61]	SPQ 160	148,9 [5.86]	21,33 [.84]
SP 200	148 [5.83]	SPQ 200	154 [6.06]	26,67 [1.05]
SP 250	154,5 [6.08]	SPQ 250	160,9 [6.33]	33,33 [1.31]
SP 315	164 [6.46]	SPQ 315	170 [6.69]	42,67 [1.68]
SP 400	174,5 [6.87]	SPQ 400	180,9 [7.12]	53,33 [2.10]

Standard Rotation
 Viewed from Shaft End
 Port A Pressurized - CW
 Port B Pressurized - CCW

Reverse Rotation
 Viewed from Shaft End
 Port A Pressurized - CCW
 Port B Pressurized - CW



MOUNTING

Oval Mount (2 Holes)

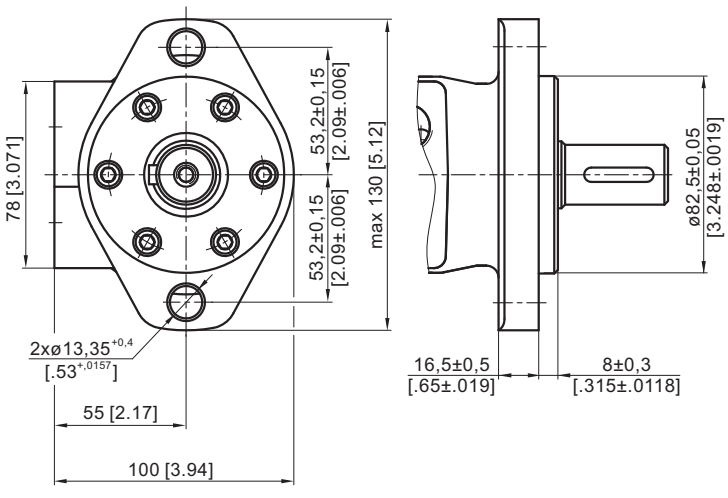

Q Square Mount
(4 bolts)

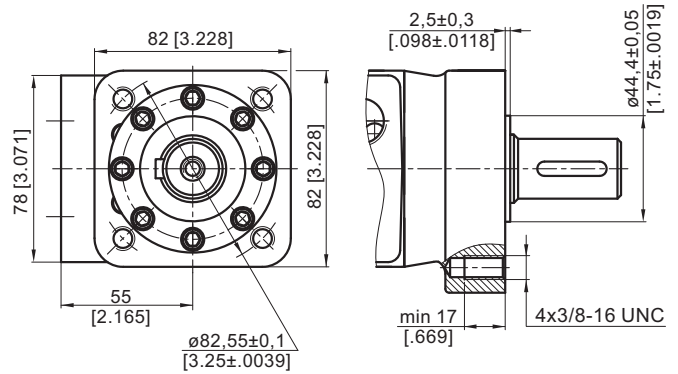

SHAFT EXTENSIONS

C - ø25 straight, Parallel key A8x7x30 DIN 6885
Max. Torque 34 daNm [3010 lb-in]

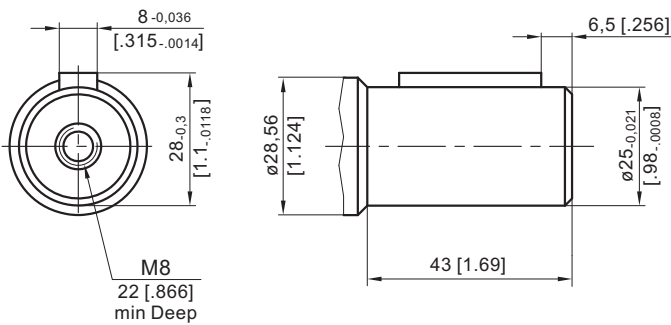

CO - ø1" straight, Parallel key 1/4"x1/4"x1" BS46
Max. Torque 34 daNm [3010 lb-in]

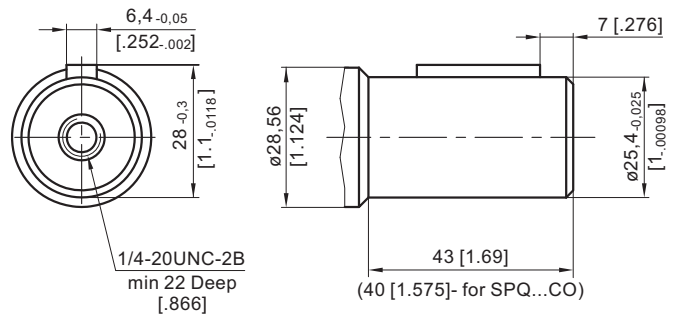

SH - splined, BS 2059 (SAE 6B)
Max. Torque 40 daNm [3540 lb-in]

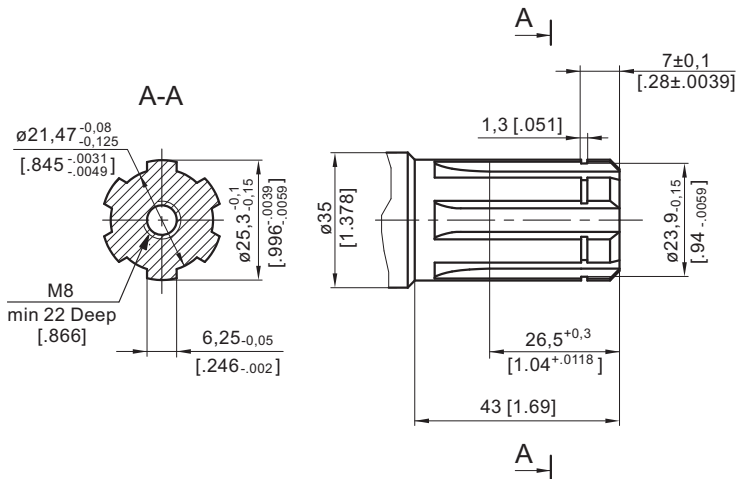

MAX. PERMISSIBLE SHAFT SEAL PRESSURE

Max return pressure without drain line or max. pressure in drain line

— - continuous operations
- - - - intermittent operations

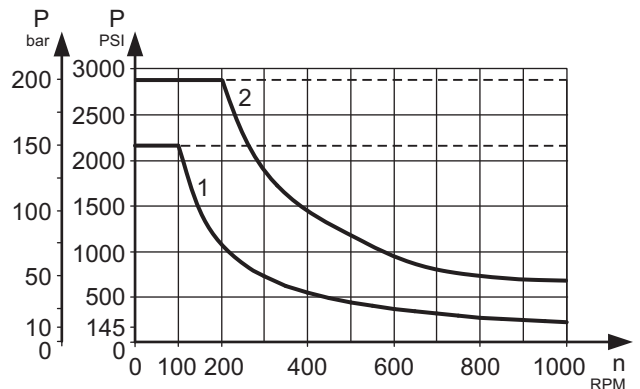

1: Curve for Standard Shaft Seal

2: Curve for High Pressure Seal ("U" Seal)



PERMISSIBLE SHAFT LOADS

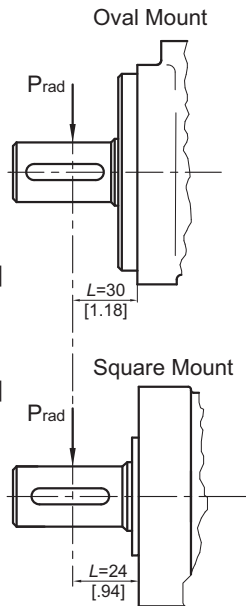

$P_{max}=150 \text{ daN}$
[330 lbs]

$P_{max}=200 \text{ daN}$
[440 lbs]

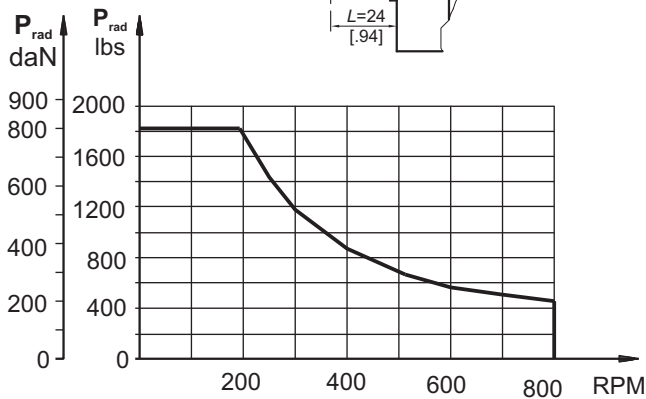

Radial Shaft Load P_{rad} for C, CO Shaft Extensions by $L=30 \text{ mm}$ [1.18 in] (24 mm [0.94 in])

The permissible radial shaft load depends on

- Speed (n)
- Distance (L) from the pointload to the mounting flange
- Mounting flange version

$$\text{Oval mount: } P_{rad} = \frac{800}{n} \times \frac{24300}{91,5+L} \text{ [daN]}^*$$

$$\left[\frac{800}{\text{RPM}} \times \frac{2150}{3.6+L} \text{ [lbs]} \right]$$

$$\text{Square mount: } P_{rad} = \frac{800}{n} \times \frac{24300}{97,5+L} \text{ [daN]}^*$$

$$\left[\frac{800}{\text{RPM}} \times \frac{2150}{3.84+L} \text{ [lbs]} \right]$$

* $n \leq 200 \text{ RPM}$; max $P_{rad} = 800 \text{ daN}$ [1800lbs]
 $n \geq 200 \text{ RPM}$; $L < 55 \text{ mm}$ [2.2 in]

ORDER CODE

1	2	3	4	5	6
SP					

Pos.1 - Mounting Flange

- omit - Oval mount, two holes
- Q** - Square mount, four bolts - 3/8-16 UNC

Pos.2 - Displacement code*

50	- 49,5 cm ³ /rev [3.02 in ³ /rev]
80	- 79,2 cm ³ /rev [4.83 in ³ /rev]
100	- 99,0 cm ³ /rev [6.04 in ³ /rev]
125	- 123,8 cm ³ /rev [7.55 in ³ /rev]
160	- 158,4 cm ³ /rev [9.66 in ³ /rev]
200	- 198,0 cm ³ /rev [12.10 in ³ /rev]
250	- 247,5 cm ³ /rev [15.10 in ³ /rev]
315	- 316,8 cm ³ /rev [19.30 in ³ /rev]
400	- 396,0 cm ³ /rev [24.16 in ³ /rev]

Pos.3 - Shaft Extensions**

- C** - $\varnothing 25$ straight, Parallel key A8x7x30 DIN6885
- CO** - $\varnothing 1$ " straight, Parallel key $1/4$ "x $1/4$ "x $1/4$ " BS46
- SH** - $\varnothing 25,3$ splined, BS 2059 (SAE 6B)

Pos.4 - Shaft Seal Version

- omit - Standard shaft seal
- U** - High pressure shaft seal

Pos.5 - Special Features (see page 120)

Pos.6 - Design Series

- omit - Factory specified

NOTES:

- * For the Function Diagrams data please look at "M+S Hydraulic" Catalogue for MP motors, pages 18+24.
- ** The permissible output torque for shafts must not be exceeded!

The hydraulic motors are manganophosphatized as standard.