

Characteristic curve

(Measured when using HLP46, $t_{oil}=40^{\circ}\text{C} \pm 5^{\circ}\text{C}$)

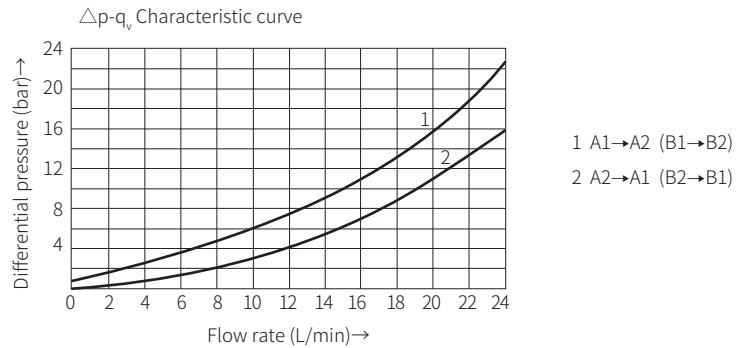

01

Component size

Size unit: mm

Model Z2S4...6XJ/...

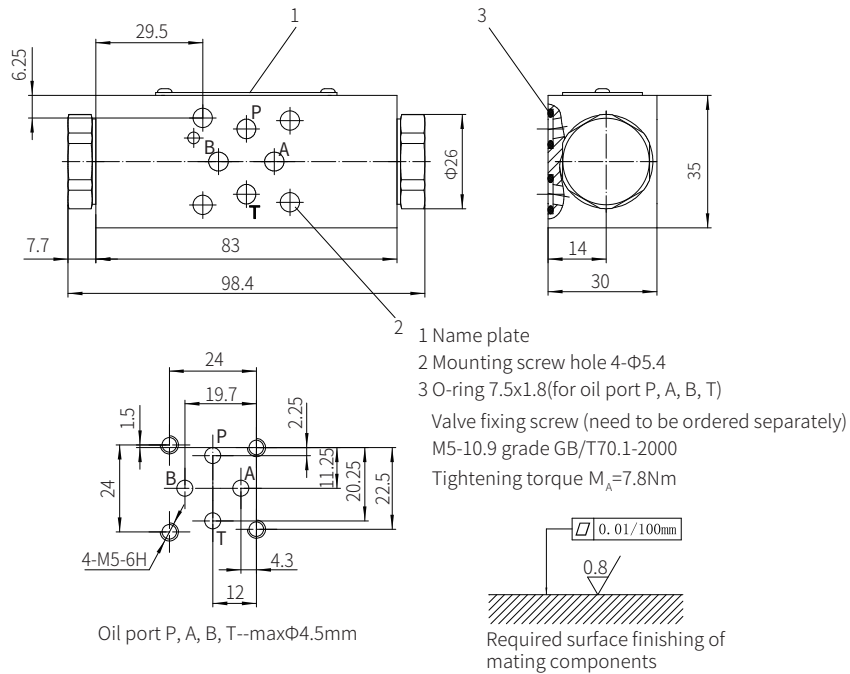

030

Modular Hydraulic Control Check Valve

Model: Z2S6...6XJ



- ◆ Size 6
- ◆ Maximum working pressure 315 bar
- ◆ Maximum working flow 60 L/min

Contents

Function description, sectional drawing	02
Models and specifications	03
Functional symbols	03
Technical parameters	04
Characteristic curve	04
Component size	05

Features

- For vertical stacking installation
- One or two working oil ports blocked for leakage-free as required.

031

Function description, sectional drawing

The Z2S type is a superimposed structure hydraulically controlled check valve. This type of valve can keep one or two working oil ports leak-free even if it works for a long time.

There is a free flow in the direction A1 to A2 and B1 to B2 but closed in the opposite direction. When the oil flows from A1 to A2 or B1 to B2, the control spool (1) is moved to the right or left and pushes the valve spool (2) away from its seat. In order to ensure the valve spool (2) to be closed safely, the oil must flow from B2 to B1 or from A2 to A1. The working oil port of the directional valve must be connected to the oil tank in the neutral position (see circuit example).

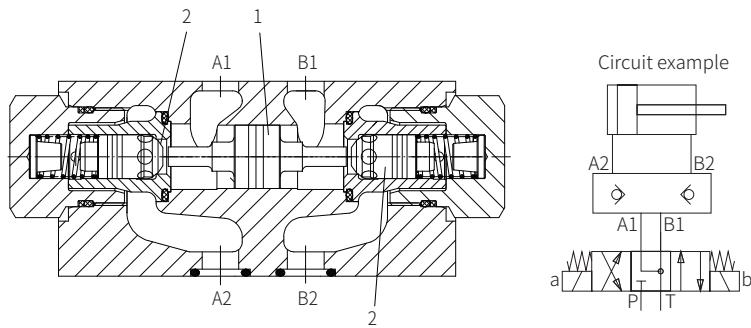

Model Z2S6...6XJ/(without pre-opening)

1 Control spool, area A2
2 Valve spool, area A1

Version "S055" (with pre-opening)

This valve is set-up with an additional pre-opening. The control spool (1) will be moved to the right by applying pressure to port X.

To do this, it should push the ball (5) away from the valve seat firstly, then push the spool (2). Now the valve allows fluid to flow from B to A as well.

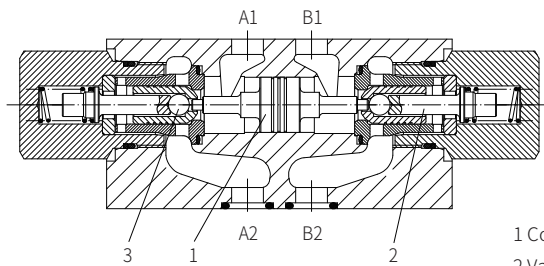

Model Z2S6...-6XJ/S055 (with pre-opening)

1 Control spool, area A2
2 Valve spool, area A1
3 Pre-opening, area A3.

Models and specifications

Z2S	6			6X	J		*
modular hydraulic control check valve							more information in text
size 6	=6						No code= without pre-opening S055= with pre-opening
leakage-free blocking in oil port A and B	=-						sealing material NBR seals
oil port A	=A						FKM seals
oil port B	=B						(consult for other seals)
cracking pressure							Rekith
1.5 bar	=1						
3 bar	=2						
7 bar	=3						
					J=		60 to 69 series installation and connection size unchanged

Functional symbols

(①= Valve side, ②= Subplate side)

Model Z2S6A...

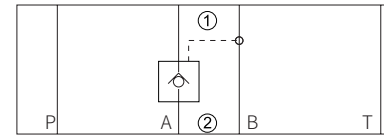

Model Z2S6 -...

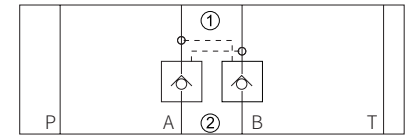

Model Z2S6B...

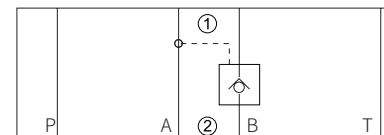

Technical Parameters

Overview		
Weight	kg	about 0.8
Installation position		Optional
Environment temperature range	°C	-30 to +80 (NBR seal) -20 to +80 (FKM seal)
Hydraulic		
Maximum working pressure	bar	315
Cracking pressure in free flow direction		See characteristic curve
Maximum flow	L/min	60
Flow direction		See functional symbols
Oil fluid		Mineral oil (HL, HLP) ¹⁾ in accordance with DIN 51524; Fast living organisms degraded oil according to VDMA 24568; HETG (Rapeseed oil) ¹⁾ ; HEPG(Polyethyleneglycol) ²⁾ ; HEES (Synthetic Fats) ²⁾
Oil temperature range	°C	-30 to +80 (NBR seal) -20 to +80 (FKM seal)
Viscosity range	mm ² /s	2.8 to 500
Cleanliness of oil		The maximum allowable pollution level of oil is ISO4406 Class 20 / 18 / 15
Area ratio		A1/A2=1/3.5; A3/A2=1/12.5 (See section view above)

1) For NBR seal and FKM seal.

2) Only for FKM seal.

3) The oil must meet the cleanliness degree requested by the components in the hydraulic system.

Effective oil filtration can prevent failure and increase the service life of the components.

Characteristic curve

(Measured when using HLP46, $\vartheta_{oil}=40^{\circ}\text{C} \pm 5^{\circ}\text{C}$)

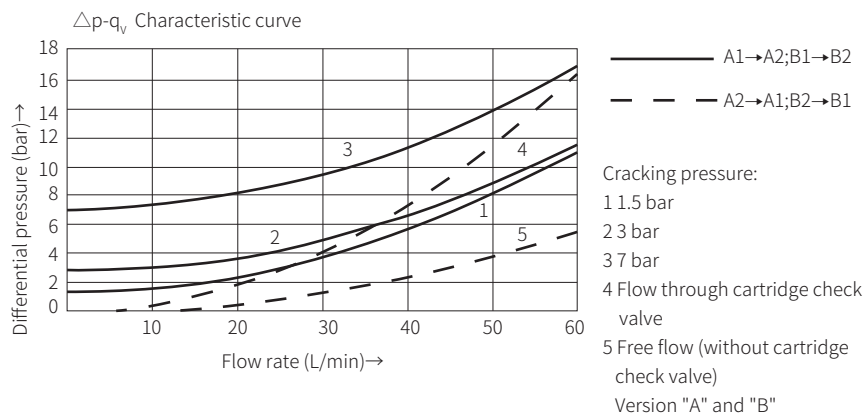

Component size

Size unit: mm

Model Z2S6...-6XJ/...

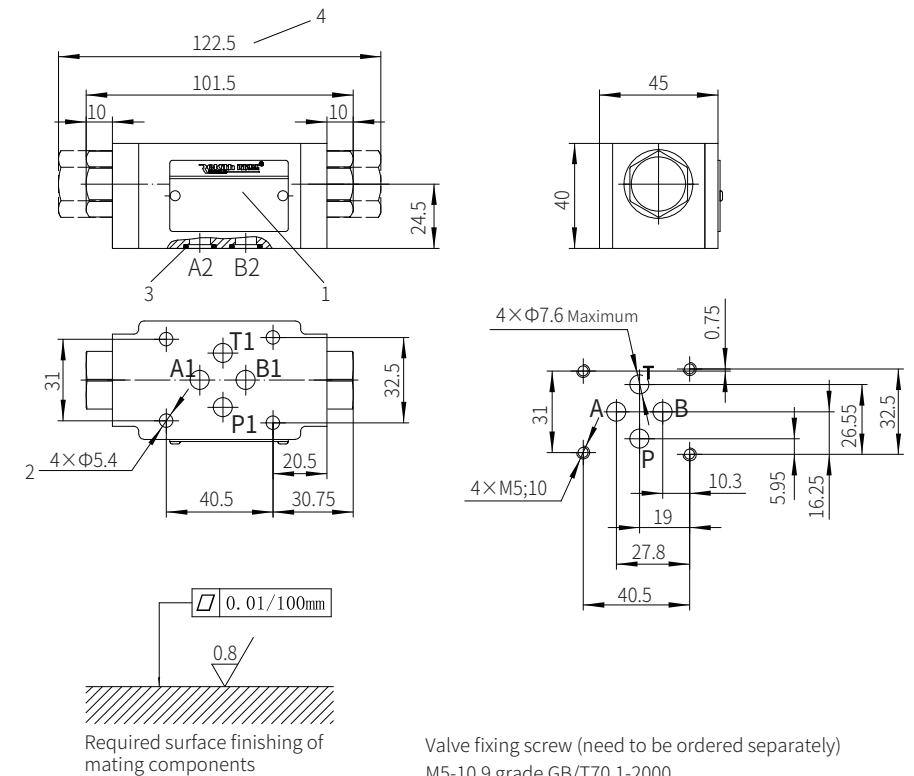

It must be ordered separately if connection subplate is needed.

Subplate model:

G341/01 (G1/4"); G341/02 (M14x1.5)

G342/01 (G3/8"); G342/02 (M18x1.5)

G502/01 (G1/2"); G502/02 (M22x1.5)

Valve fixing screw (need to be ordered separately)

M5-10.9 grade GB/T70.1-2000

Tightening torque $M_A=7.8\text{Nm}$

1 Name plate

2 Mounting screw holes

3 O-ring 9.25x1.78 (for oil port A2, B2, P2, T2)

4 Size of model Z2S6...-S055